

A COOPERATIVE ARCHITECTURE DESIGN SYSTEM VIA COMMUNICATION NETWORK

Yuhua Luo*, Ricardo Galli*, David Sánchez*, Antonio Bennassar*, Antonio Carlos Almeida**, Miguel Dias***

*University of Balearic Islands, Palma de Mallorca, Spain

** Instituto de Telecomunicações, Instituto Superior Técnico, Portugal

*** ADETTI, ISCTE, Lisbon, Portugal

Email: yuhua@m3d.uib.es

1. INTRODUCTION

The architectural production process is extremely complex. A great amount of communication is necessary between the design team members, the constructor and all other parties involved. During the design phase, many iterations of decomposition and integration of different parts and specialties of the design are necessary. Many errors can occur during these iterations. In addition, the architectural design and construction team is usually a temporal combination for a particular project. The project teams are usually geographically spread out which makes the communication even more difficult. The current business model of the AEC industry is facing the difficulties in the communication and information integration.

The M3D system is a first time attempt to provide a communication and integration tool for an architectural design team. It promotes a new business process in the AEC industry. It is a higher level CSCW system particularly for 3D architectural design [Luo98a, Luo98b, Luo99a, Luo99b, Galli00]. It provides cooperative working sessions to connect the long distance team members to have on-line visualization and modification of the design. The system provides a rich set of editing and integration operations focused on architects and engineers necessities.

2. TOWARDS A NEW BUSINESS PROCESS IN AEC INDUSTRY

Business Process Model in Architectural Production

The life cycle of a building can be decomposed into five separate stages: (i) planning, (ii) design, (iii) construction, (iv) use (including operation and maintenance) and (v) demolishing [ISO 96]. The first two phases deal with the production of architecture. They can be further refined into four distinct moments prior to the construction, where information is manipulated in digital or paper form. They are preliminary study, conceptual design or base program, overall design, detailed design. During these phases scheme designs are detailed in 2D and/or 3D; cost estimation is revised; material is selected and schedule of construction work is established.

Starting from the overall design phase, different specialties intervene in the design process. The most important ones are architecture, structural engineering, water and

sewage, energy, air conditioning and telecommunications. However, for specific cases, other specialties may take part in the process, such as acoustic engineering, special illumination, internal and external data communications and others. The M3D system addresses all of them, since its focus is in the integration of the geometrical designs of different specialties, prior to the construction phase.

Problems in the Current Business Processes

An analytical study of the architecture business processes, carried in Portugal, Spain, Italy and United Kingdom [Dias98] has helped us to identify some problems in the above mentioned processes. In these countries, the architect is responsible for the conceptual development and produces an initial geometric proposal. It is then converted into CAD data files. This drawing basis information is supplied to all specialties (structural engineering, water and sewage, energy, air conditioning, etc), so that they are able to incorporate it into their specialized projects. This is what we refer to as project decomposition. After this stage, an integration of all the different specialized project designs is performed. A design verification process then takes place to produce a coherent, compatible and integrated geometric design of the project. We identify that it is this iterative cycle of project decomposition and integration in both overall design and detailed design process causes the major design problems:

- Geographically dispersed project teams need to cooperate in the design process and there is no integrated technology to provide assistance in cooperation during design.
- Many design related errors during the overall design and detailed design processes, are found only until the construction phase.
- The verification process is currently performed manually, because of the lack of such functionality in the existing CAD tools.

According to our study, the errors within these iterations can be classified in two cases. The first case is the omission of information – undefined geometry, which causes indeterminacy. The second case is the contradiction of the geometric information when two or more incompatible elements occupy the same space at the same time.

These errors are due to two types of reasons, namely insufficient functionality in the available CAD tools and the methodological mistakes; both are associated with the current business process practice. These frequent inconsistency errors are mostly detected only in the building phase of the project, where the solutions to correct them are extremely costly. It may end up with total dissatisfaction for the client or the city authority. According to our view, these errors could have been detected in the earlier architectural project stages, to minimize the occurrence of such problems during construction work.

New Design Processes and Innovative IT Solutions in Architecture

As a solution to these identified problems, M3D proposes the re-engineering of current business processes and the complementary introduction of innovative IT solutions, which will enable the improvement of the traditional CAD tools in the architecture domain. These IT tools can be enumerated as:

- A collaborative multi-site, multi-user VRML based editor for 3D design integration and editing, the M3D Editor, described in detail in this paper.
- A design verification system for architecture [Dias99].
- A web-based client-server construction database [Bas99].

Our framework is based on some methodological principles that introduce changes in the current design processes. In this respect, the intervening actors in such process are required to:

- Use 3D information: each specialty should produce its design contribution in 3D, using available third party CAD packages.
- Use a standard neutral data format (VRML) for geometric and topologic information with the third party CAD tools.
- Adopt the ISO standard 13567 “Technical product documentation-Organisation and naming of layers for CAD” for naming CAD objects and layers.

3. OVERVIEW OF THE SYSTEM

The M3D system includes a cooperative 3D Editor, the M3D Editor, a shared database and a cooperative and communication support platform. The major function of the M3D Editor is for integration and editing of the design. Its to support the cooperative work not only includes the distributed-collaborative visualisation, but also, and more important, the on-line modification of CAD objects. The shared, database is for information storing and retrieval of the whole architectural project.

System Architecture

The M3D system is designed as a fully distributed, multi-user, multi-layered system connected by communication network [Luo99]. From the user’s point of view, the M3D system is composed of a set of different applications that are replicated in each computer on each site. Sets of such workstations are connected through high to low band network to form the system. The current target is to achieve good interactive performance in ISDN connections because it is the standard set-up for European architecture small and medium size enterprises. Figure 3.1 shows the general configuration of the M3D system.

The M3D system follows the peer-to-peer network communication model. The layers of the M3D system and its corresponding layers to the OSI layers are shown in Figure 3.2. The cooperative support layer is application and network

independent. The hosts participating in a session have the same set of resources and replicas of the applications.

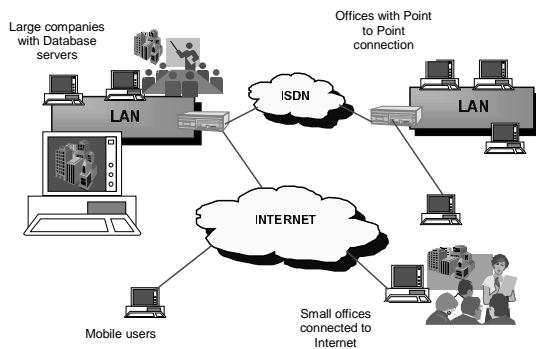

Figure 3.1: General Configuration of the M3D system

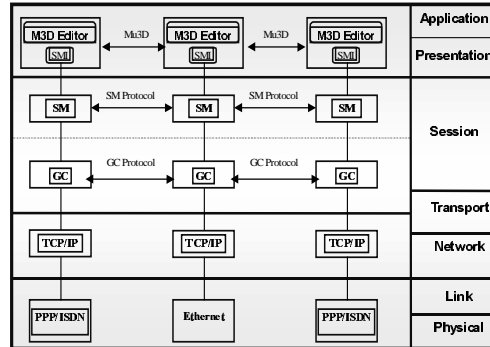

Figure 3.2: The layered structure of the M3D system and the corresponding OSI layers

In terms of operation, The cooperative and communication support platform hides the network configuration from the applications. The platform’s session control mechanism supports the application’s inclusion and control in cooperative environments. The group communication tasks are performed by the group communication (GC) sub-layer.

4. THE INTEGRATION AND EDITING TOOL

The M3DEditor is an integration and editing tool which allows the architects and engineers to work together on a cooperative session (Figure 4.1).

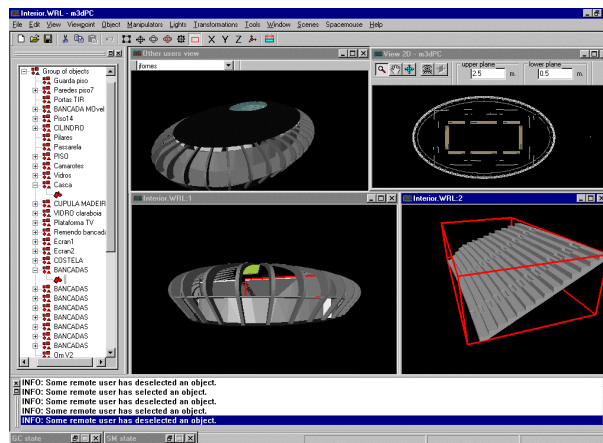

Figure 4.1 The M3D Editor

The editor has two modes of working: the online cooperative editing mode and the off-line editing mode. During the online working session, the participants are able to integrate their design, discuss specific design problems, and modify it

interactively. The off-line mode is for the chief architect or project manager to prepare an online working session between the members of the team.

As mentioned before, the editor uses the standard VRML as the native file format. It can open and insert any design in this format. Almost all modern CAD tools can generate VRML files as output. The services provided by the M3D Editor can be grouped into basic groups such as visualisation service, editing service and consistency checking service.

The visualisation service provides the capability for interactive discussion and detection of problems in the design model. The navigation into the 3D models follows the virtual reality paradigm. Every user is represented on the screen by an avatar. The users can also visualise other participants' views in the cooperative session. A *2D map* of the scene is provided to avoid user's disorientation in navigating in 3D. The user can locate himself to any location in the 2D map of the design while the 3D view will appear on the screen. The user can change his position and orientation either on the 2D map or on the 3D screen.

An object can be identified by a standard colour code. The editor follows the ISO 13567-1,2 standard to code the name of the objects. ISO codes can be automatically assigned to the objects, and standard colours can be assigned to an object, according to the ISO name. Object codes can be hidden. To improve the communication between the partners in the session, the editor provides support for textual annotations. To make a section of a design is important in the architectural work. The editor provides support to visualise sections of the design, with any orientation. These sections can be interactively manipulated. Measurement facility is also provided by the editor to give the user an exact knowledge of the dimension of the object.

Editing service provides the ability to modify the design, and to show the changes to all the participants in the session. The editor provides to integrate designs of different specialities, such as architectural design, structural design, etc. Some major inconsistencies can immediately be visible after the integration. Modifying the position, orientation and scale for every object is possible in two ways: interactive manipulation, in a visual manner, and exact numerical introduction of the modification. The shape of any single object can also be modified. Common functions in an interactive system, such as undo, and clipboard operations, can be performed in the editor. Undo can be performed on modifications insertions and deletions. Clipboard operations (cut, copy and paste) can be performed as in any interactive system.

The M3DEditor also provides mutual exclusion service to guarantee that only one user is allowed to modify an object at a time. Selection is the basic mechanism to assure mutual exclusion. The local and remote selections are differently. A cooperative session can be held between two or more users, located in remote sites.

The editor also allows changing the working bandwidth, making it scalable to several network configurations.

5. COOPERATIVE SUPPORT AND COMMUNICATION

Distributed architecture

The M3D system has a cooperative support platform (JESP). It provides group communication and control services to generic distributed applications. The platform is completely distributed such that, during the cooperative sessions, all the participating sites have the same set of platform resources (control and communication), as well as application resources. If the users share the same applications, all sites have a similar set of application and JESP processes (replicas) running over the respective operating systems.

Instead of relying on a distributed visualization system to maintain the same virtual environment to all users (the role of the central server), our approach relies on the communication of application events among all sites, which are processed locally by the application replicas, producing local results to users. If consistency is guaranteed, all the users will see the same sequence of changes produced in the applications, throughout the session. This approach also reduces significantly the required bandwidth to run the cooperative sessions, because the exchanged messages are much shorter than in the centralized approach.

The local replica of the distributed architecture is depicted in Figure 5.1. The JESP platform provides services to the local replica of the application layer (here, the M3D Editor), through *service access points* (SAP), encompassing all the available service primitives.

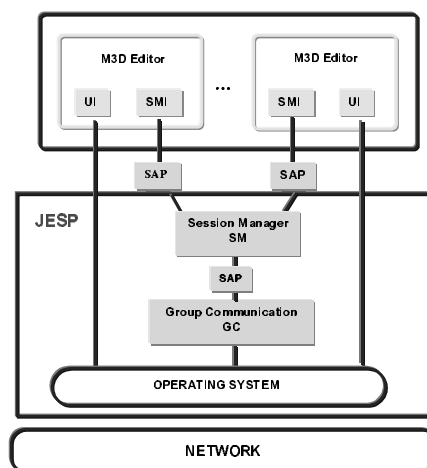

Figure 5.1: Local structure of the Editor and JESP

Cooperative support and communication services

The platform was primarily designed to provide synchronous interactions among users, i.e. simultaneous operation of a group of users spread over remote locations.

The services for distributed cooperative sessions are: service multiplexing, data consistency control, late and early member admissions, dynamic application environments, support for graceful death of one or more sites and multi-point communications. In addition, the M3D application does not use the data consistency control mechanism available at the platform, but instead, an application protocol Mu3D is implemented at the application level [Galli00].

Conference control

The initiation, management and termination of a cooperative work session requires a number of operations performed by the users that are not part of the real objective (in terms of work) of the joint sessions. That is, to initiate a session, one of the users has to perform a number of tasks prior to the session, where groups of users are specified and the applications to be shared are configured and launched. Also, the external control of the JESP platform (e.g. start and termination of the platform over the required machines, monitoring of communication problems) has to be performed by an outside and independent system. The main functions of the meta-conferencing system is to help users to tackle with the conference management tasks.

Conceptually, the meta-conferencing system has two entities running on each site: the Group Daemon (**GD**) and Graphic User Interface (**GUI**). The functions of the GD include the management of all local processes related to the conference (both platform processes and application processes). The GD communicates with each one of the entities of the platform (JESP) in order to obtain reports about the underlying running sessions. Occasionally, errors may be communicated and reported to the users. Also, the GD sends special requests to the platform when, for example, a new user is willing to joint a running session, or one of the users is willing to quit. The addition of a new application to a running session is also managed through the GD. The main role of the GUI is to serve as the conferencing interface with the users, acting as the visible part of the meta-conferencing system.

6. CONCLUSIONS AND ACKNOWLEDGEMENT

We sincerely hope that the M3D system we present in this paper will contribute to a significant change of the traditional architecture design process. We expect that by using such a system and a new business process it supports, the occurrence of errors can be minimized. The construction cost and time can therefore be reduced.

This work is supported by the Esprit (IST) project No. 26287 M3D funding and the Spanish CICYT project funding TIC-98-1530-CE and Tel. 96-0544. The authors would like to thank all the members in the M3D project partner teams UIB, ADETTI, EDC, OA, IDOM and ARQMAQ for all their cooperation and enthusiasm of the M3D work.

References

- [Alme95] A. Almeida and C. A. Belo. "Support for Multimedia Cooperative Sessions over Distributed Environments." *Proc. Mediacomm'95*, Society for Computer Simulation, Southampton, April, 1995.
- [Bas99] Bas Tummers et. al., Report on the development of M3D database, Esprit Project No. 26287 (M3D), Deliverable 3.1.1, October, 1999.
- [Cad1] CAD Studio, "VRMLout for AutoCAD", <http://www.cadstudio.cz/indexuk.html>
- [Galli97] R. Galli, P. Palmer, M. Mascaro, M. Dias, Y. Luo, "CODI - A System for Cooperative 3D Design." *Proceedings of 1997 IEEE Conference on Information Visualization*, pp. 286-293. London, August 27-29, 1997.
- [Gall00] R. Galli, Y. Luo. " Mu3D: A Causal Consistency Protocol for a Collaborative VRML Editor", *Proceeding of the VRML'2000 Symposium*, Monterey, CA, Feb. 2000, ACM SIGGRAPH.
- [Luo98a] Yuhua Luo, Ricardo Galli, Miguel Mascaro, Pere Palmer, "Cooperative Design for 3D Virtual Scenes," *Third IFCIS Conference on Cooperative Information Systems (CoopIS'98)*, August 1998, New York, U.S.A.
- [Luo98b] Y. Luo, R. Galli, M. Mascaro, P. Palmer, F. J. Riera, C. Ferrer, S. F. Alves, "Real Time Multi-User Interaction with 3D Graphics via Communication Network," *Proceedings of IEEE 1998 Conference on Information Visualization*, July 1998, London.
- [Luo99a] Y. Luo, R. Galli, A. Almeida, M. Dias, A Prototype System for Cooperative Architecture Design, *Proceedings of IEEE Symposium on Information Visualization*, July 1999, London.
- [Luo99b] Y. Luo, D. Sánchez, S. Alves, M. Dias, R. Marques, A. Almeida, J. Silva, J. Manuel , , B. Tummers (EDC), Ed. R.Galli, "*M3D technical specifications*", ESPRIT Project No. 26287 M3D, Deliverable 1.2, April 1999.
- [Sall97] José Miguel Salles Dias, Ricardo Galli, António Carlos Almeida, Carlos A. C. Belo, and José Manuel Rebordao. "mWorld: A Multiuser 3D Virtual Environment." *IEEE Computer Graphics and Applications*, Vol. 17, No. 2, March/April 1997.
- [ISO96] "Product Data Representation and Exchange, Part 230 - Building Structural Frame: Steelwork", ISO TC184/SC4/WG3 N551, Working Draft12 October 1996.
- [Dias98] Dias, J.M.S. et al, "*Architecture Process model*", ESPRIT Project No. 26287 (Multi-site cooperative 3D design system for architecture) Deliverable 1.1.2, , Sept. 1998.
- [Dias99] Dias, J. M. S., Gamito, M., Silva, J., Fonseca, J., Luo, Y., "Interference Detection in Architectural Databases", Short paper Eurographics 99, Milan, September 1999.